



CATALOG NO. 502 WALL RACK

ONLY A SCREWDRIVER IS
NECESSARY FOR COMPLETE ASSEMBLY

PARTS LIST

HARDWARE - (for each bracket assembly)

- 5 ea. 1/4 x 3/8" round head machine screws
- 2 ea. 1/4 x 1" round head screws
- 1 ea. No. 10-24 x 3/8" round head screw
- 3 ea. No. 10 x 1 1/2" round head sheet metal screws (for mounting rack to wall).
- 2 ea. Black caps for ends of hanger bar

OTHER PARTS in each carton

- 8 ea. 3/4" diameter shelf tubes
- 1 ea. 1" diameter hanger bar

PARTS - (for each bracket assembly)

- 1ea. Backstrip for mounting
- 1ea. Top shelf support brace
- 1ea. Bottom shelf support brace with loop for hanger bar
- 1ea. Top shelf support, 1" square tube, with 4 large holes and only 1 threaded 1/4" hole
- 1ea. Bottom shelf support, 1" square tube, with 4 large holes and 2 threaded 1/4" holes

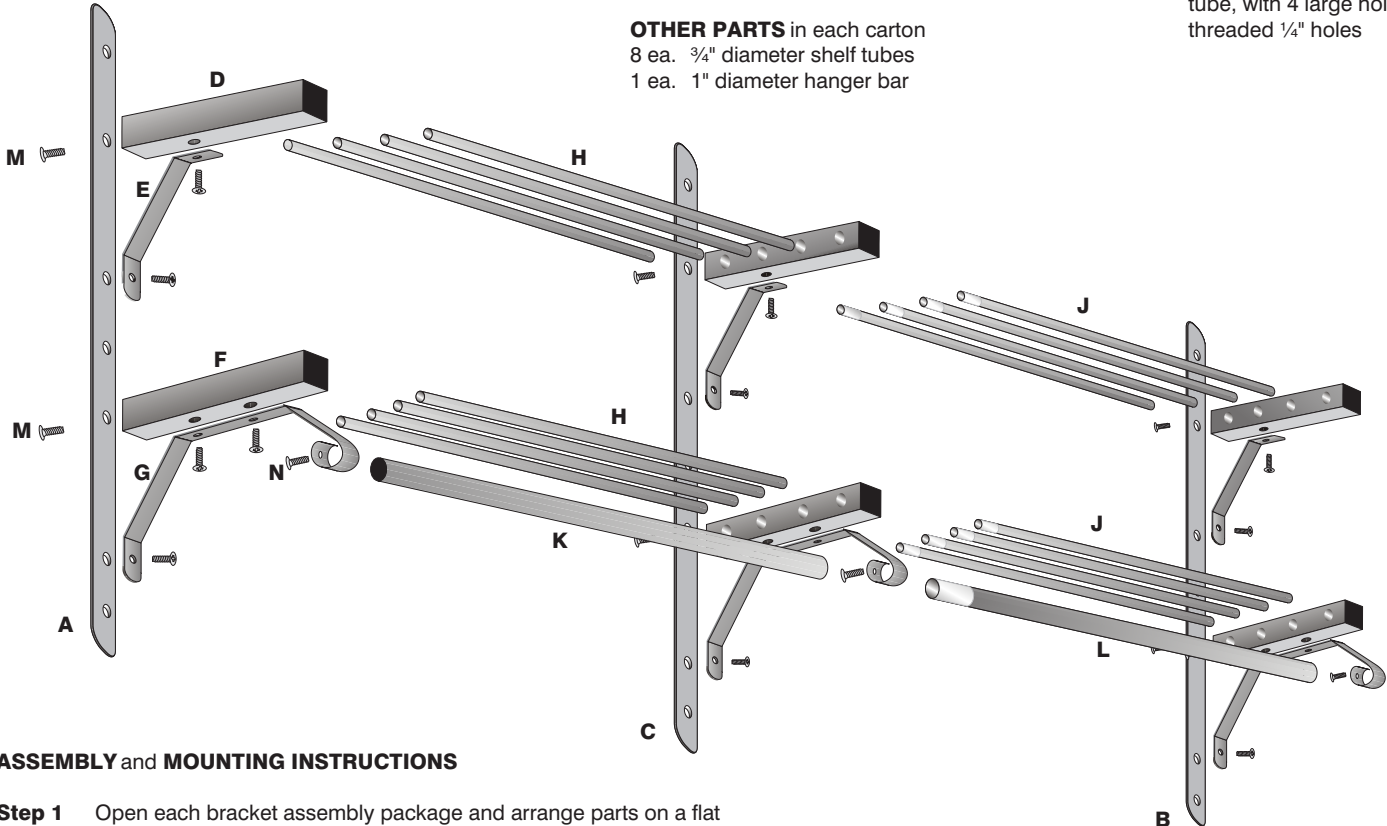

ASSEMBLY and MOUNTING INSTRUCTIONS

- Step 1** Open each bracket assembly package and arrange parts on a flat surface. Note that the large 3/4" diameter holes in the square shelf support tubes and slot in the back strip "A" face to the right on the left end bracket, and to the left on the right end bracket "B" go all the way through on center brackets "C".
- Step 2** Assemble bracket as per diagram (parts A, D, E, F, G) without tightening screws.
- Step 3** Securely tighten the two 1" round head screw "M" that hold parts D and F to A.
- Step 4** Assemble the other brackets (as above).
- Step 5** Tighten securely all other screws except the small screw in the loop where the hanger bar will go.
- Step 6** Mount the left bracket "A" to the wall making sure that the large holes face the right.
- Step 7** Insert the tubes "H" into the holes in the bracket. Use the tubes that are not swaged.

- Step 8** Attach the center bracket "C" (for racks more than 36 inches) and mount to the wall. The center bracket has holes coming out of both sides of the square tubing. Be sure that the bracket is as far to the left as it can be.
- Step 9** Insert the swaged tubes "J" into the holes on the right side of the center bracket. Press them in firmly all of the way.
If your rack has more than two sections. Repeat steps 8 & 9 for each add-on section.
- Step 10** Attach the remaining end bracket "B" and mount it to the wall.
- Step 11** Add the hanger Bar "K" and "L" locking in place with the screws provided, "N".
- Step 12** Press the black caps into the ends of the hanger bar.

See the 502 Wall Mounted Coat Rack at www.Glaro.net