

Glaro

CATALOG NO. 501 WALL RACK

ONLY A SCREWDRIVER IS
NECESSARY FOR COMPLETE ASSEMBLY

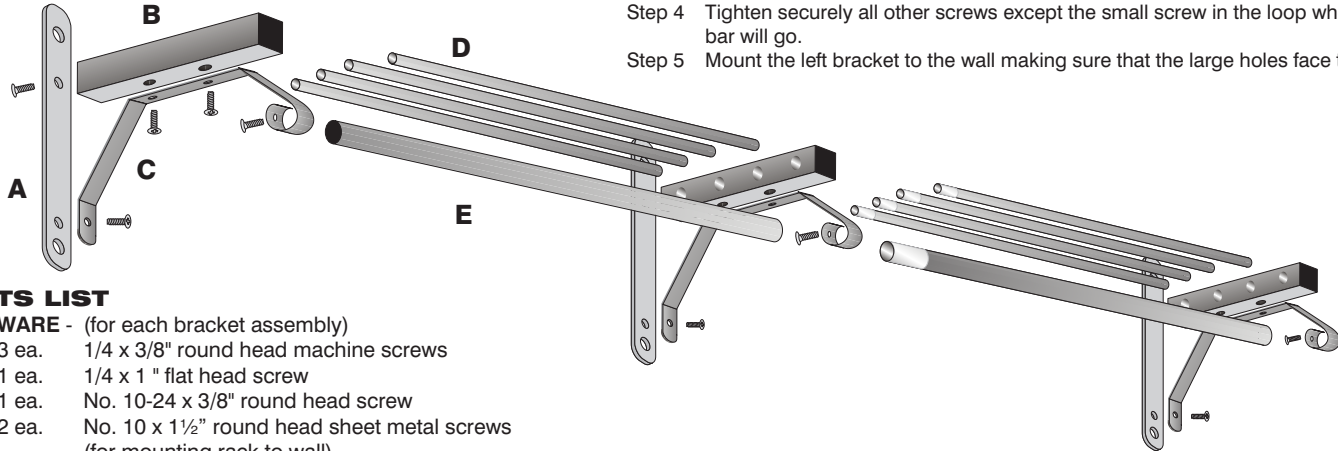

PARTS LIST

HARDWARE - (for each bracket assembly)

- 3 ea. 1/4 x 3/8" round head machine screws
- 1 ea. 1/4 x 1" flat head screw
- 1 ea. No. 10-24 x 3/8" round head screw
- 2 ea. No. 10 x 1 1/2" round head sheet metal screws
(for mounting rack to wall)
- 2 ea. Black caps for ends of hanger bar

OTHER PARTS in each carton

- (D) 4 ea. 3/4" diameter shelf tubes
- (E) 1 ea. 1" diameter hanger bar

PARTS - (for each bracket assembly)

- (A) 1 ea. Backstrip for mounting
- (C) 1 ea. Shelf support brace with loop
for hanger bar.
- (B) 1 ea. Shelf support, 1" square tube,
with 4 large holes and 2 threaded 1/4" holes.

ASSEMBLY and MOUNTING INSTRUCTIONS

- Step 1 Open each bracket assembly package and arrange parts on a flat surface as below. Note that the large 3/4" diameter holes face to the right on the left end bracket, to the left on right end bracket, and go all the way through on center brackets.
- Step 2 Assemble bracket as per diagram without tightening screws.
- Step 3 Tighten securely the 1" flat head screw that holds part 'B' to 'A'
- Step 4 Tighten securely all other screws except the small screw in the loop where the hanger bar will go.
- Step 5 Mount the left bracket to the wall making sure that the large holes face to the right.

- Step 6 Insert the tubes that are not swedged into the holes in the bracket,
- Step 7 Attach the center bracket (for racks more than 36 inches.) and mount to the wall. The center bracket has holes on both sides of the square tubing, Be sure that the bracket is as far to the left as it can be.
- Step 8 Insert the swedged tubes into the holes on the right side of the center brackets. Press them in firmly all the way.

If your rack has more than two sections. Repeat steps 7 & 8 for each add-on section.

- Step 9 Attach the remaining end bracket and mount it to the wall.
- Step 10 Add the 1" diameter round hanger bar, locking in place with the screws provided.
- Step 11 Press the black caps into the ends of the hanger bars.

See the 501H Wall Mounted Coat Rack at www.Glaro.net

GLARO.NET • 888-512-1850